

SALVIS Salamander Classic and Classic Pro



SSR RH C
SSR HL C



SSR RH C-Pro
SSR HL C-Pro

Installation and Operating Instructions

Dear Customer,

Please read this installation and operating instructions carefully before using your new Salamander. They contain important instructions for the correct installation and operation and must always be available at the work station.

1. Introduction	4
1.1 Note regarding devices with Hilight heaters	4
1.2 Proper use	4
1.3 Danger Zone	4
1.4 Safety instructions	4
1.5 Conformity	4
1.6 Product labeling	4
1.7 Protection class	4
2. Installation	5
2.1 Technical specifications (Standard)	5
2.2 Setup, connections	5
2.2.1 Table top unit	6
2.2.2 Wall mount	6
2.3 Start up	6
2.4 Electrical connection	6
2.5 Dimensional drawings	7
3. Tips for operation safety	8
3.1 Daily operation	8
3.2 Risk of injury	8
3.3 Risk of damage	8
4. Operation with mechanical short-term timer	9
4.1 Operating modes	9
4.2 Turning on the Appliance	10
4.2.1 Plate recognition without timer	10
4.2.2 Plate recognition with timer	10
5. Operating the Salamander with electronic short-term timer	11
5.1 Control panel with electronic short-term timer	11
5.2 Manual operation	11
5.3 Automatic operation via plate recognition and timing control	12
5.4 Automatic operation via plate recognition without timing control	13
6. Completion of operation	14
7. Cleaning and care	14
8. Errors and remedies	15
9. Customer Service	15
10. Maintenance	15
11. Disposal information	15

1. Introduction

1.1 Note regarding devices with Hi-light heaters

Automatic ON/OFF switching during operation!

- The hilight heaters are equipped with a built-in temperature monitoring system.
- This temperature monitoring system limits the maximum temperature and thus prevents an overheating of the hilight heater.
- The device function is not impaired by this.

1.2 Proper use

The device is intended exclusively for the skilled preparation of food.

- Au gratin
- Baking
- Keep warm

1.3 Danger Zone



All surfaces of the reflector area and the top will become hot.

The device must not be operated near or on top of flammable parts (tops or walls).

1.4 Safety instructions

This device requires supervised operation.

The items to be cooked must not touch the heating elements.

1.5 Conformity

Notes

The device has been manufactured as per VDE/ GS and European standards (EN).

1.6 Product labeling

The type plate including the serial number, type name and CE symbol is located on the right side of the device.

Documenting the type plate data

Please write the type plate data on the following lines prior to installing the device. Please indicate this data when making a service request for the device. This will expedite the response to your question.

Type:

Device Number:

Year of construction:

1.7 Protection class

Degree of protection against water: IPX4

2. Installation

2.1 Technical specifications (Standard)

Technical specifications	Salamander with mechanical short-term timer	Salamander with elektronik short-term timer
Part No.	Tubular heating element (RH): SA373200, SA373206 HiLight heating element (HL): SA373201, SA373207, SA373230, 954942, 877838, 878381, 887352, ¹⁾ 975540, ¹⁾ SA373221	Tubular heating element (RH): SA373210, SA373214, 893145, ¹⁾ ²⁾ SA373224 HiLight heating element (HL): SA373211, SA373215, 956813, 877839, 887353, 893144
Total connection value	RH = 3,6 kW / HL = 4,6 kW	
Voltage	400 V 2N 50/60 Hz ¹⁾ 230 V 1N 50/60 Hz	
Fuse	2 x 16 A ¹⁾ 1 x 16 A ^{1) 2)} 1 x 20 A	
Device sound level	less than 70 dB (A)	
Weight	approx. 40 kg	

Rights reserved to make technical changes!

2.2 Setup, connections

- Please observe the local kitchen regulation.
- The installations must be performed according to the manufacturer's installation instructions and the prevalent technical regulations.
- Have the setup and introduction of the devices performed by the authorised customer service.

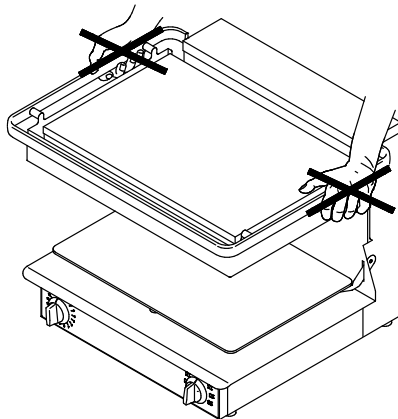

Caution!

Do not carry the Salamander by the reflector.

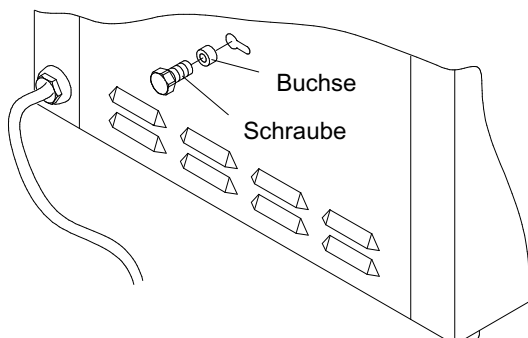

Remove the transport safety latches prior to the initial operation.

Attention: The nut could fall.

- Unscrew the screw
- Remove the nut and the screw from the key-hole.

2.2.1 Table top unit

Setting up the table top unit

- Horizontal and not sensitive to vibrations,
- not on heated or flammable surfaces,
- not against flammable walls
- We recommend placing the table unit onto a small subframe, part no. SA 373209 .

Due to heat radiation, maintain a minimum distance of 200 mm to the left and right to devices, walls or objects.

☞ Pull the protective film off the device. Remove glue residue using cleaning or washing petrol.

2.2.2 Wall mount

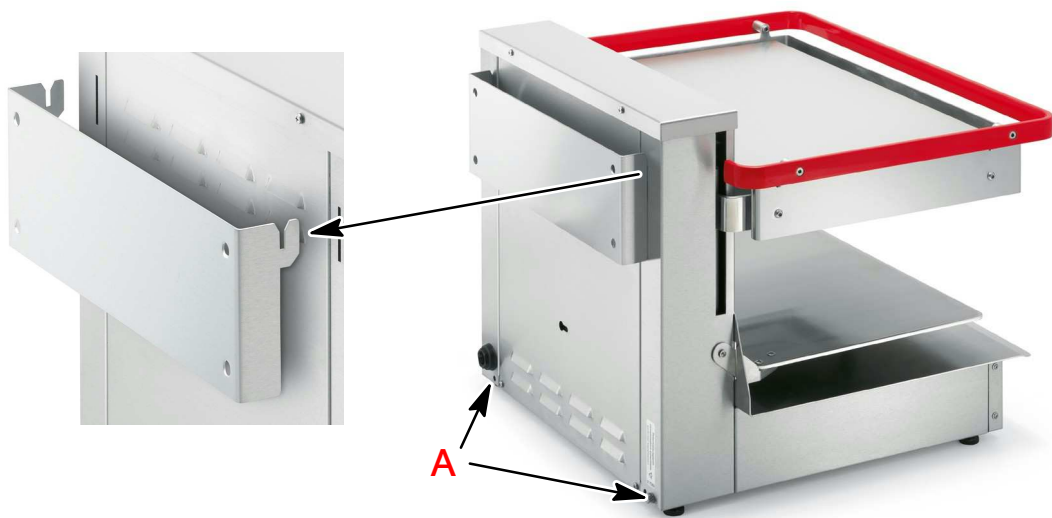

The Wall mount profile also serves as the drilling template!
Screw to the wall using a level.

Screw in the 2 included spacer screws „A“!
Fine tune the alignment by tightening or loosening these screws „A“.

2.3 Start up

- ☞ Clean the device prior to the first use using degreasing cleaners.
- ☞ Dry the cleaned parts and surfaces with a soft cloth.
 - Cleaning, see page 14, Chapter 7.

2.4 Electrical connection



The electrical connections must be made by an authorised electrician

- as per the regulations of the VDE 0100.
- as per the regulations of the power companies.

The mobile power cable must conform to at least H 07 RN-F.

An electrical switch (main switch)

- must be easily accessible and preswitched on the installation.
- The switch must separate the device from the power supply effectively and completely.
- The contact opening must measure at least 3 mm.

For safety reasons, we recommend installing a power failure protective switch (FI) > 10 mA.

Observe the data on the type plate when making the electrical connections!

Include the device into the potential equalization system. The effectiveness must be inspected as per VDE 0 190.

2.5 Dimensional drawings

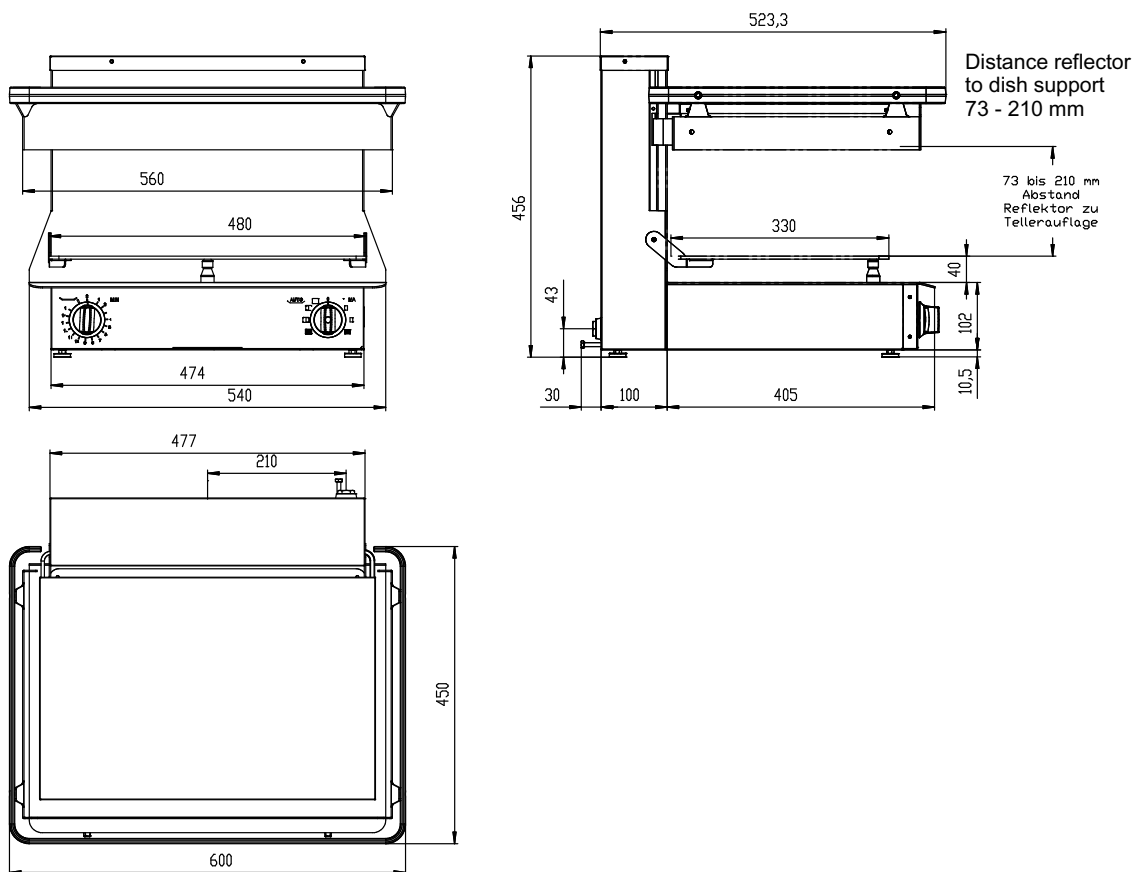

3. Tips for operation safety

3.1 Daily operation



- The device is intended for commercial use and must only be used
 - by trained personnel,
 - if the device is supervised,
 - for the purpose indicated in the operating instructions,
 - if there is no malfunction.
- The device must only be used outside if there is a roof and sufficient wind protection! Protect the device and the connection cables from moisture!
- Do not use the device as a shelf or storage space!
- The user is solely liable for damages caused by use outside the intended purpose.
- If you cannot resolve functional errors using the section „Errors and Remedies“ on page 15 in Chapter 8., switch off the device and notify customer service.

3.2 Risk of injury

- Caution: the device is hot during and after operation!
- Use caution when removing plates and containers: The plates and containers are hot!

3.3 Risk of damage

- The food must not touch the heating elements!
- Only use heat-resistant dishes or containers!
- Do not place food directly on the top plate! Only place food in heat-resistant plates and containers on top plate!
- Do not spray or clean the device with a water hose, high-pressure cleaner, high-pressure steam cleaner or steam cleaner!
- Following longer down times, have the device checked by customer service for functionality.

4. Operation with mechanical short-term timer

4.1 Operating modes

- You have several ways of controlling the heater:

Manually

(not with type 893144, 893145, SA893144, SA893145)

- The heater is switched on immediately as per setting of the selector switch and remains turned on until it is switched off. The short-time clock and the plate switch are out of order.

Automatic

- Automatic with plate switch:

(Selector switch to AUTO, time switch on  (continuous operation).

The heater is switched on by adding the plate and switches off when it is removed.

- Automatic with plate switch and short-time clock:

After setting the short-time clock and placing the plate, the heater is turned on.

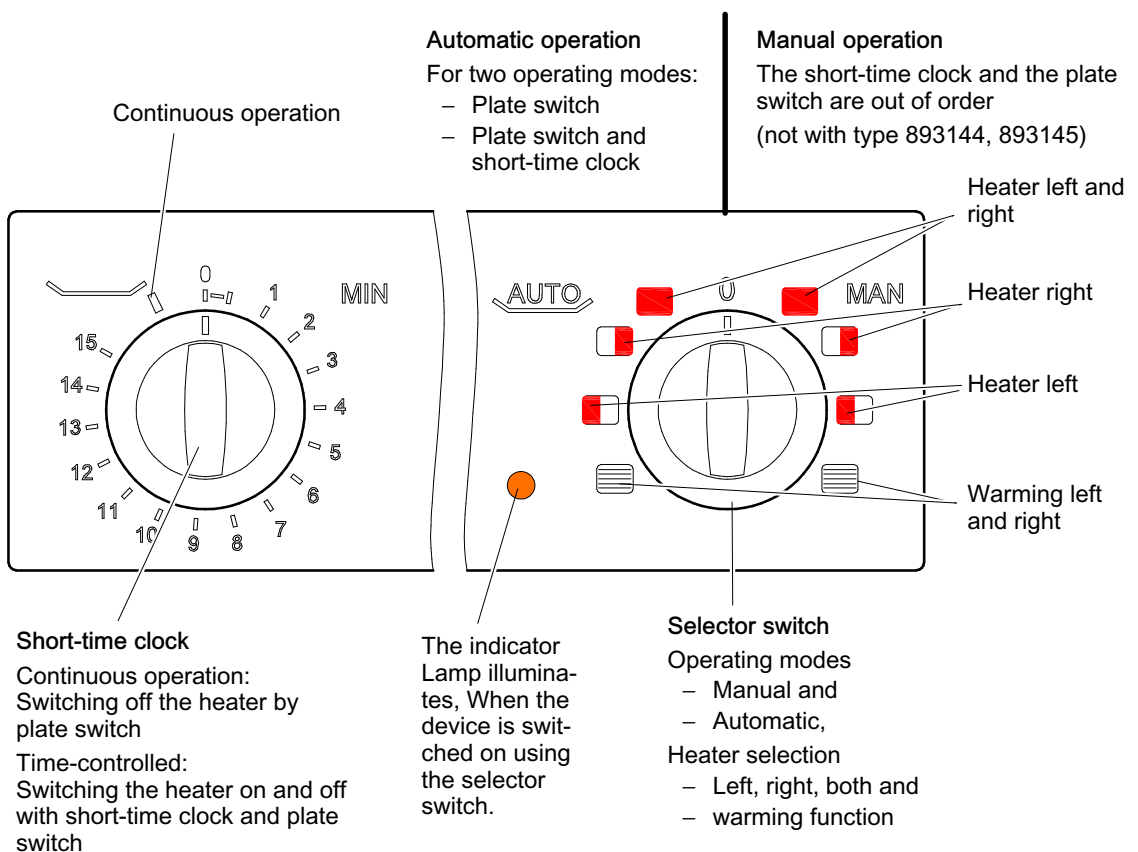

4.2 Turning on the Appliance

Example: Right heater, operating mode automatic with short-time clock and plate switch.

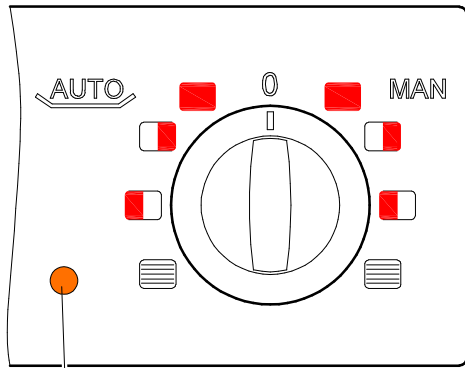

Indicator lamp

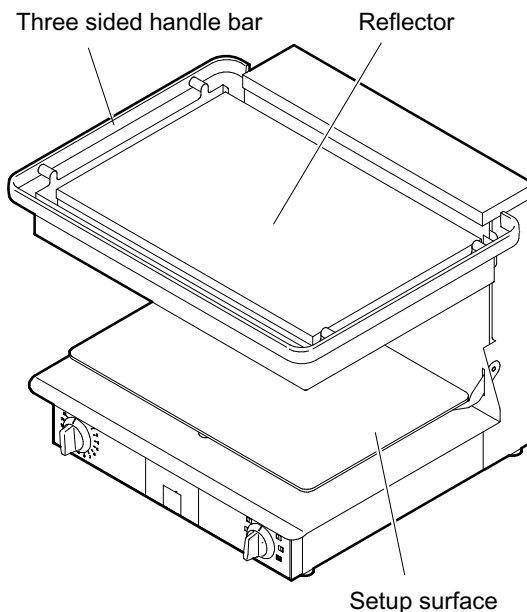

Three sided handle bar

Reflector

Setup surface

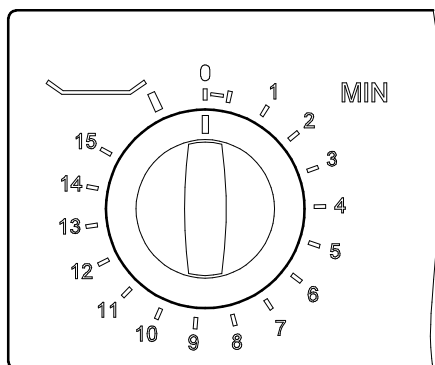

4.2.1 Plate recognition without timer

- ☞ Turn the selector switch to the left to the operating mode “Automatic”, “Heater on the right”.
- ☞ Slide the reflector all the way to the top.
- ☞ Turn the time switch to the left to pos. Plate  .
- ☞ Place the plate with food onto the surface.
 - The indicator lamp illuminates.
 - The right heater switches on.
- ☞ Lower the reflector to the desired position.
 - The food must not touch the heating elements!
 - Remove plate/platter as needed. The heater will switch off automatically.

4.2.2 Plate recognition with timer

- ☞ Turn the selector switch to the left to the operating mode “Automatic”, “Heater on the right”.
- ☞ Slide the reflector all the way to the top.
- ☞ Place the plate with food onto the surface.
- ☞ Set the short-time clock to the desired time.
 - The indicator lamp illuminates.
 - The right heater switches on.
- ☞ Lower the reflector to the desired position.
 - The food must not touch the heating elements!
 - After the preset period of time has elapsed, signal sounds and the heater switches off.
- ☞ Remove plate/platter.

Note for switching off the heater

- The heater switches off, when
 - the short-time clock time has elapsed or
 - when the plate is taken out before the time has elapsed.

5. Operating the Salamander with electronic short-term timer

5.1 Control panel with electronic short-term timer

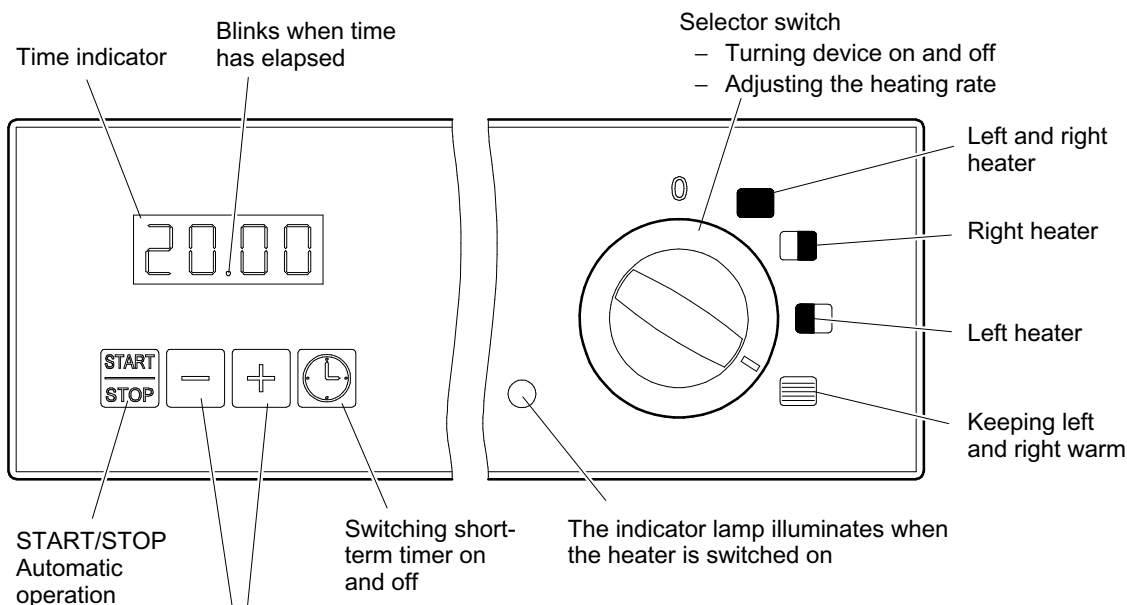

Setting the time

Press the minus or plus key and hold - rapid forward and reverse.
Press key once to move in 5-second steps.

Timer/Memory Function (Target time)

- Automatic storage of the target time takes place automatically as soon as the short-time clock has run down for a few seconds.
- The stored target time is preserved even after shutting down the unit.

5.2 Manual operation

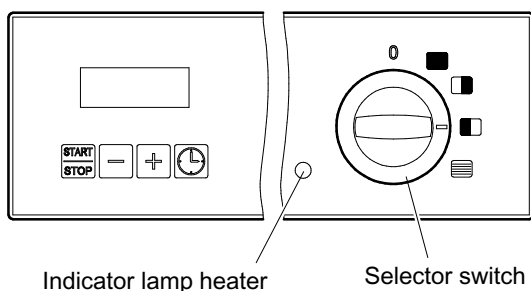

Switching device on

- ☞ Turn the selector switch to the desired heating output.
- ☞ The heater turns on.
 - The heater indicator lamp illuminates.
 - The short-term timer remains off.
 - The short-term timer and the plate recognition are deactivated.
- ☞ Place the plates with food on the surface.
- ☞ Lower the reflector to the desired position.
 - The food must not touch the heating elements!

Completing the cooking cycle



Careful when removing the plates! The heater and the plates are hot! Wear heat-resistant gloves! Slide the reflector into the top position to remove the plates.

5.3 Automatic operation via plate recognition and timing control

Automatic start of the set time and switching on the heater by

- placing a plate (plate recognition) or by
- pressing the START/STOP key.

The heater will switch off

- automatically after the set time has elapsed, or
- by removing the plate, or
- by pressing the START/STOP key.

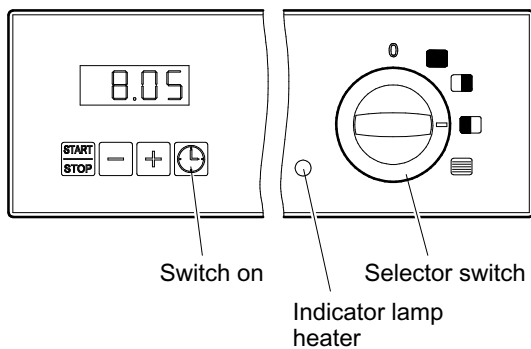

Switching device on

- ☞ Turn the selector switch to the desired heating output.
- ☞ The heater turns on.
- ☞ Switch on short-term timer.
- ☞ The heater shuts off.
- ☞ CSet the desired time via the minus and plus keys.

Starting the cooking cycle

- ☞ Place the plates with food on the surface.
- ☞ The heater turns on.
 - The indicator lamp for the heater illuminates.
 - The short-term timer begins to count backwards.
 - The dot in the display blinks "8.05"
- ☞ Lower the reflector into the desired position.
 - The food must not touch the heating elements!

Completing the cooking cycle

- After the time has elapsed, the heater will shut off. For a duration of approx. 5 seconds, a signal will sound and the display blinks 0.00.
- If the time was not sufficient to heat the food, the heater can be turned on and off again by using the START/STOP key.



Careful when removing the plates! The heater and the plates are hot! Wear heat-resistant gloves! Slide the reflector into the top position to remove the plates.

5.4 Automatic operation via plate recognition without timing control

Automatic start of the set time and switching on the heater by

- placing a plate (plate recognition) or by
- pressing the START/STOP key.

The heater will switch off

- after the set time has elapsed, or
- by removing the plate, or
- by pressing the START/STOP key.

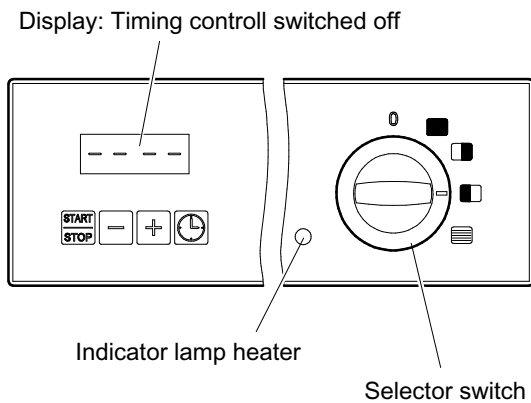

Switching device on

- ☞ Turn the selector switch to the desired heating output.
- ☞ Switch on short-term timer.
- ☞ Set infinite operation “- - - -” by means of the minus key on the time display.

Starting the cooking cycle

- ☞ C Place the plates with food on the surface.
- ☞ The heater turns on.
 - The indicator lamp for the heater illuminates.
 - The dot in the display blinks “-.-.-”
- ☞ Lower the reflector into the desired position.
 - The food must not touch the heating elements!

Completing the cooking cycle



Careful when removing the plates! The heater and the plates are hot! Wear heat-resistant gloves! Slide the reflector into the top position to remove the plates.

- If the plate is removed, the heater shuts off.
- If the plate is not removed yet, the heater can be switched off via the START/STOP key.

6. Completion of operation

- Turn the selector switch to 0 position.
- Indicator lamp goes off.
- Clean the device, see chapter 7., „Cleaning and Care“.
- Switch off the main switch.

7. Cleaning and care

Cleaning

Regular cleaning leads to an increased product life of the device.

We recommend cleaning the device on a daily basis as follows:

- Allow device to cool down
- Clean the casing with an all purpose cleaner and a damp cloth.
- Only use food-approved cleaners.

Detergents and care products

Your customer service carries suitable cleaners and care products.

These include:

- Degreasing cleansers or special stainless steel cleaners,
- Preserving stainless steel care products.

Important tips

- Do not let caustic cleansers touch the control panel and selector switches!
 - Do not spray or clean the device with a water hose, high-pressure cleaner, high-pressure steam cleaner or steam cleaner!
 - Observe the directions provided by the manufacturer of the cleaners!
 - Do not use abrasive cleaners!
 - Stainless steel must not come into prolonged contact with concentrated acids, vinegar, saline, mustard, spice blends, as this will effect the protective coating.
 - Clean stainless steel surfaces with a moist cloth and rub dry after use.
- ☞ Clean burnt foods off the stainless steel surfaces with grill cleaner.
- ☞ After using strong cleaners, thoroughly rinse the parts with water and rub dry.
- ☞ Clean the casing with degreasing cleanser or special stainless steel cleaner and rub dry with a soft cloth.

Safety instructions



Do not clean the device with a water jet or under running water; do not use steam cleaners. The Salamander is NOT watertight! Consequential damages cannot be claimed.

Always switch off the device and let it cool down before performing any maintenance work.

8. Errors and remedies

If there are malfunctions on the device, check these against the following table:

Error	Possible cause	Remedy
When switching the device on, the yellow indicator light does not illuminate.	Main switch not turned on in front of the device.	Turn on the main switch.
	The entire power supply system is missing.	Notify the power company.
	The network fuse has been tripped.	Have possible device failures check by an authorised customer service. Switch on the network fuse.

If you cannot remedy the error,

- switch off the device and remove the plug from the socket.
- do not open the casing,
- inform Customer Service.

9. Customer Service

Notify the closest service center in case of functional errors.

Avoid error messages and check the following before contacting the authorised service center:

- are the fuses in the electrical supply line functional?
- is the plug plugged in?
- is the main switch turned on?
- was the device started up properly?

Important!

Please indicate with every service call:

Type: _____

Device number: _____

This data is indicated on the type plate, which is located on the right side of the device.

10. Maintenance

- Have the device inspected and serviced on a regular basis. Maintenance tasks include: e.g. safety, functional and leakage checks.
- Installation, maintenance and repair work may only be carried out by trained electricians.
- Only use original accessories and spare parts!
- We recommend signing a maintenance contract with customer service.

11. Disposal information

- Pull the plug with defective devices. Separate the power cable and dispose of.
- Old devices are not worthless waste! By environmentally conscious disposal practices, we can regain valuable raw materials.

Artikel-Nr.: SA373218 / 7.2007 / 2.25

SALVIS AG
Nordstrasse 15
CH-4665 Oftringen
www.salvis.ch
Phone +41 62 788 18 18
Fax +41 62 788 18 98

smart cooking

